

Quick install guide

1、 Unlade, The forklift fork into the middle of the box



2、 Remove the final box, first remove the screw on the box , then use crowbar remove the box ,order is up-front-back left-right.



3、 Removal of the fixed machine wooden block, standard machine (Picture 4) please remove fixed breacket。

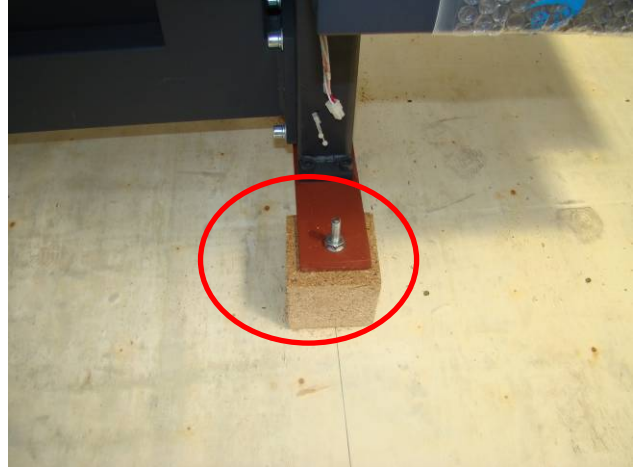
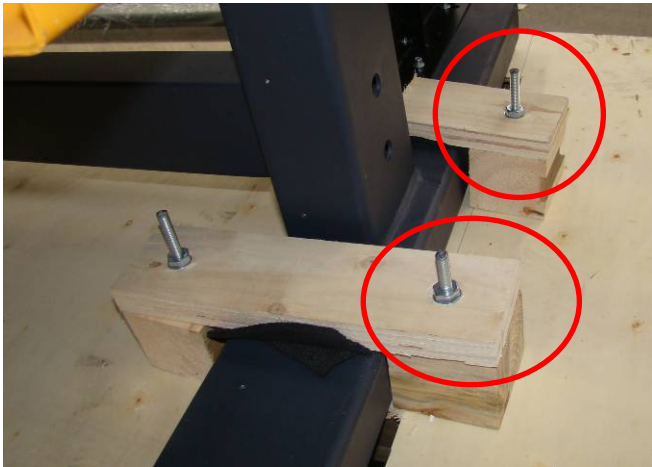

4、 Remove the chassis, install the leg.。

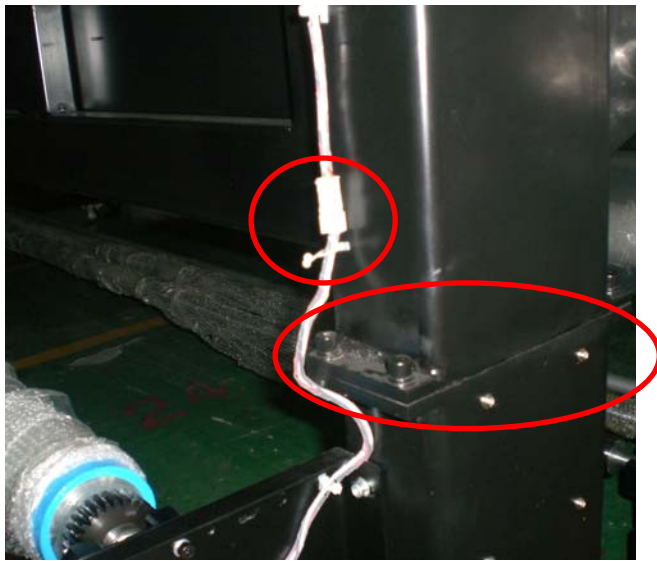
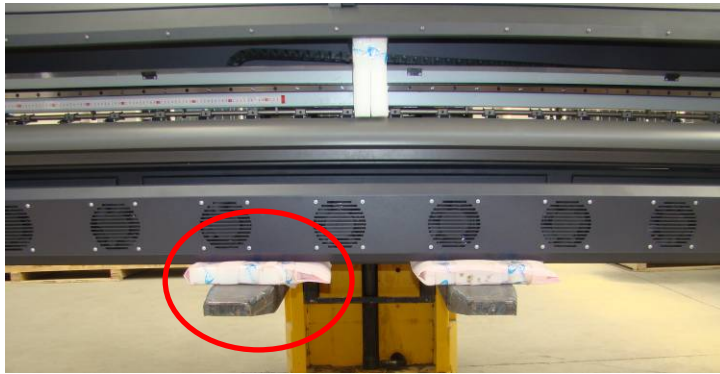

5、 Undo the wheel, put position, install shore, adjust level.

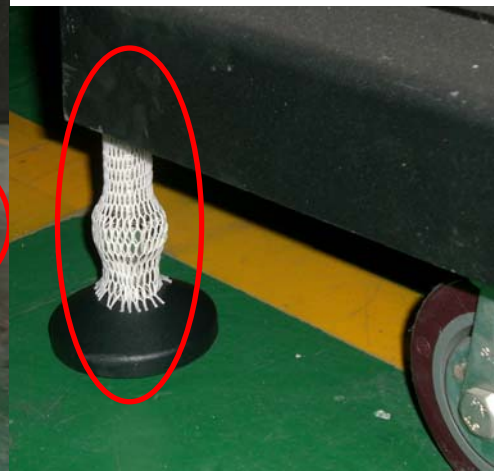

6、 install feeding system and take up roller, install vacuum!



7、 Install carriage board!

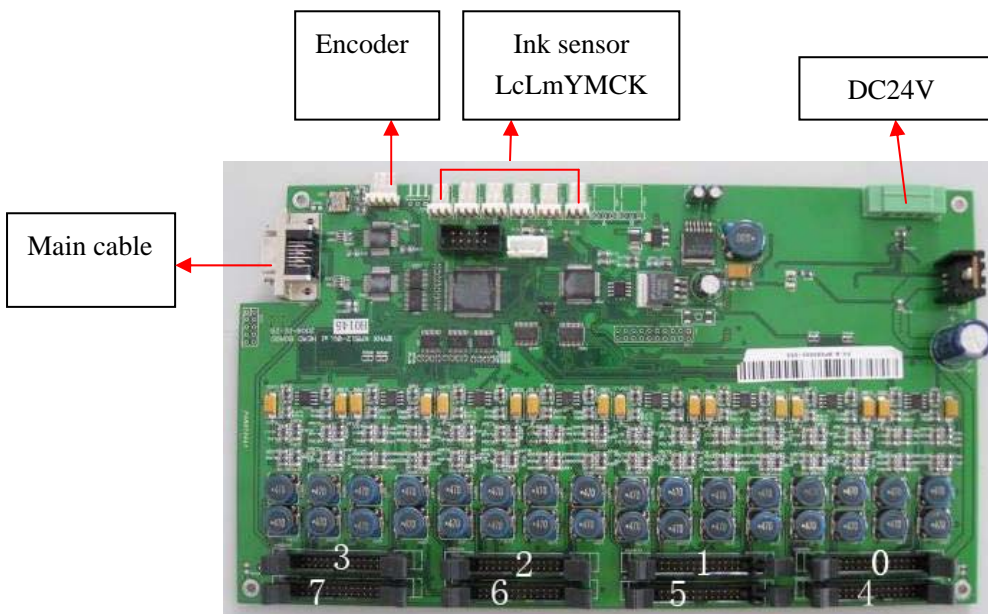

8、 Adjust the printheads soleplate!

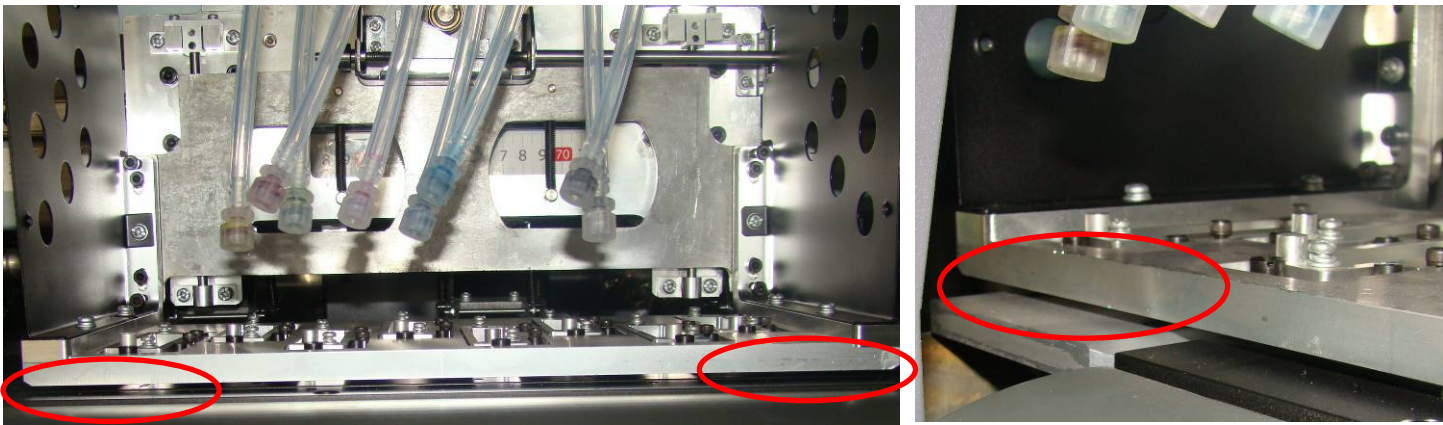

9、 Clean the ink supply system!

10. Record the printhead voltage, and pick up use which color (Selected voltage close to the same printhead placement, and selected better voltage C and M placement)

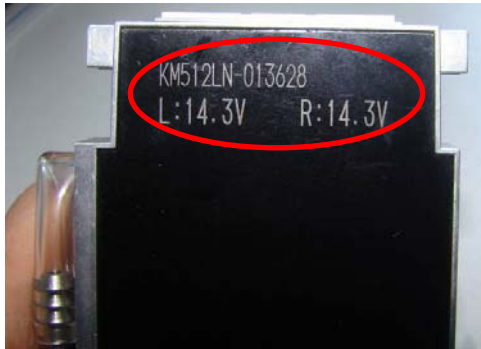

11. Install tube for printhead and printhead interface boards!

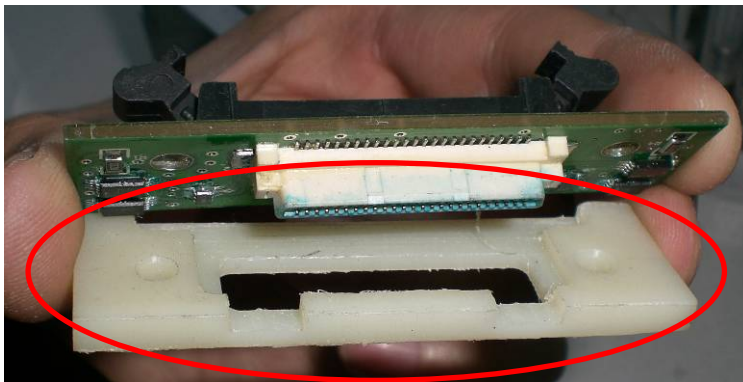
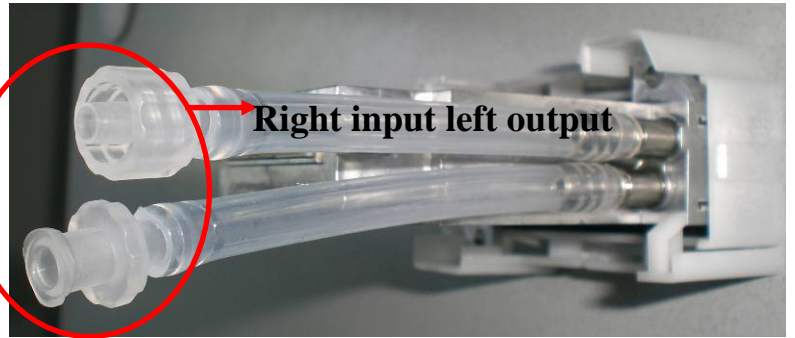

12. Install printheads and connect data cable , install the ink, push ink!

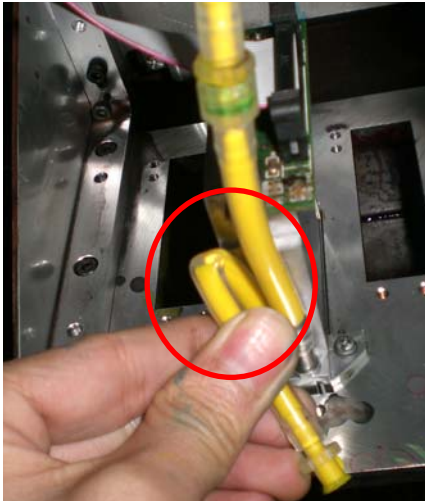
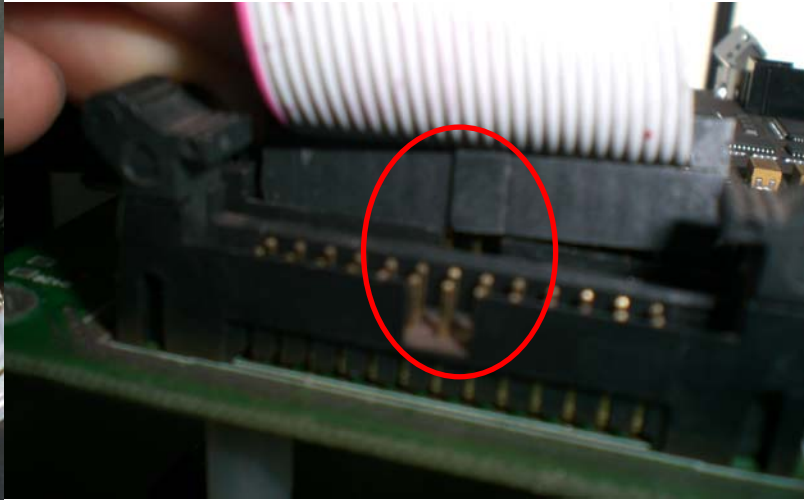
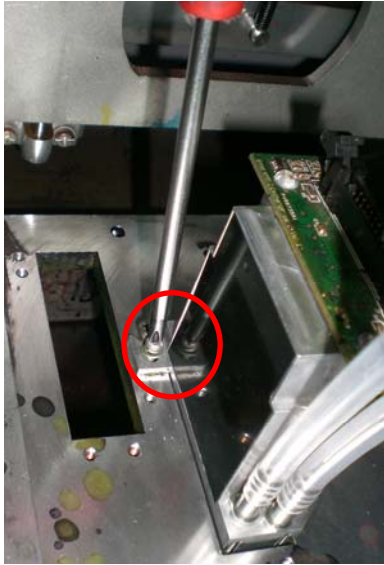
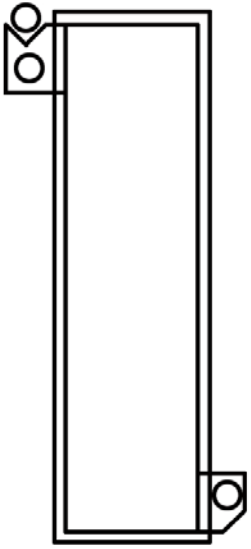

13. Install printer control software and rip software, setting the software, please click follow Hyper Link!

how to install printmanager .exe

14. Input the voltage to the software, Printmanage Tools —real setting, the printheads voltage input to the base voltage.

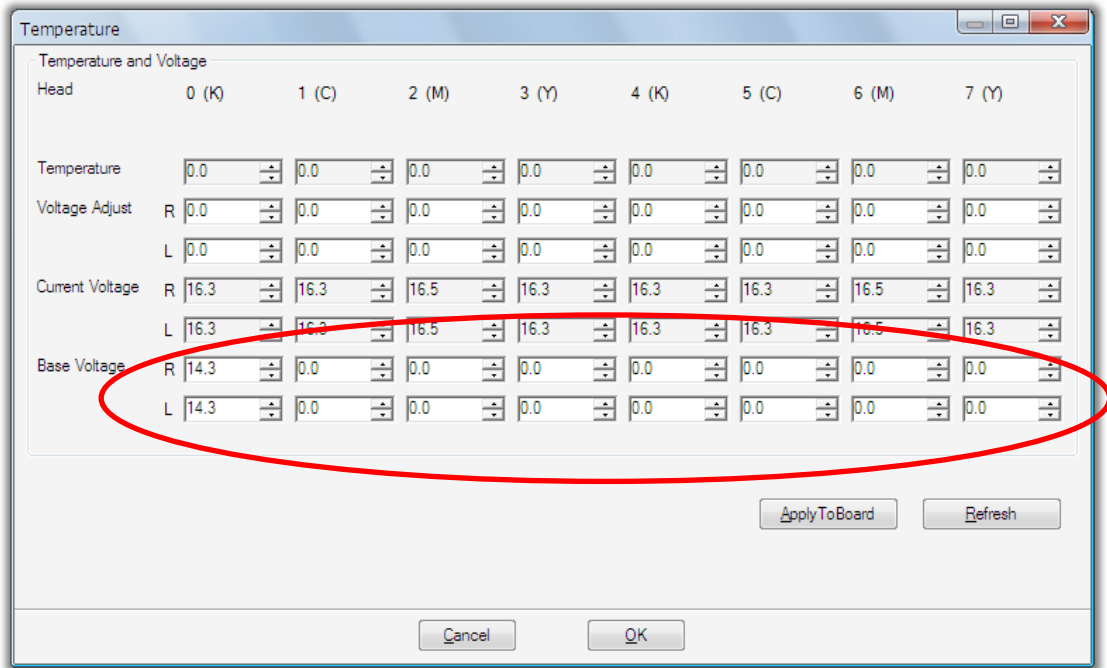

15、 Print nozzle check and calibration, please click follow Hyper Link!

[calibration guide.pdf](#)

16、 Install finish!

